

EXTERIOR ELEVATION

MAX. FRAME SIZE (IN.)	IMPACT
48" X 120"	NO
APPLICABLE FOR SINGLE UNITS ONLY	

FRAME ANCHOR REQUIREMENTS TABLE		
FRAME/CLIP TO OPENING FASTENER TYPE	MINIMUM EMBED	MINIMUM EDGE DIST.
#10 PFH screws into frame and wood substrate	1-1/4"	See pg. 2
#8 PFH Zinc treated screws into clip and wood substrate at an angle	—	—
#8 PFH Zinc treated screws into clip and frame	—	—

Installation Method
Screws thru the Frame
Sides = #10 PFH screws spaced 6" from corners and 8" on center Head = #10 PFH screws spaced 1" from corners and 8" on center Sill = None

GENERAL NOTES

1. These units have been tested, analyzed, Hallmark certified, and FBC approved.
2. Bucking, openings, and bucking fasteners must be properly designed and installed to transfer wind loads to the structure. The unit was tested with 1/2" rough opening gap.
3. These units were tested with ponderosa pine bucks, Florida building code requires preservative treated southern pine bucks.
4. All hardware and fasteners shall be in accordance with these drawings and may not vary unless specifically mentioned on the drawings.
5. These units have been tested in accordance with and meet the requirements of the Florida Building Code.
6. Impact shutters are required only with non-impact units.
7. All anchors shall be installed as specified on these drawings. Specified embedment base material shall be beyond wall finish or stucco.
8. Testing of one wood species covers all other species with an equal or higher modulus of elasticity and modulus of rupture.
9. Testing of primed covers testing of clad as long as cladding is not structural (extruded), or wraps around the gasket.
10. Testing of windows and doors with a given width and thickness of solid stiles and rails, covers products with wider and thicker solid stiles and rails provided that construction details are consistent.
11. Any fixed geometric shape that fits within the tested/approved size for a particular product type is qualified by the rectangular shape(s) provided that the frame, sash, panels, components, and construction remain the same.
12. All fixed shaped units must fit inscribed into the allowable rectangular units and be governed by allowable design pressure or the respective rectangular unit.
13. Shims need to be located a maximum of 4" from each corner and a maximum of 4" from each anchor location.

KOLBE 1323 South 11th Ave.
Wausau, WI 54401
715-842-5666
■ WINDOWS & DOORS ■

Heritage Series
XL Sterling Double Hung

FL# 25886	R&D No. 15132
Revision	Drawn By: JRK
A SES 12/16/20	Date: 12/21/17
B	Sheet: 1 of 2
C	Drawing No. 15132

Screw Installation

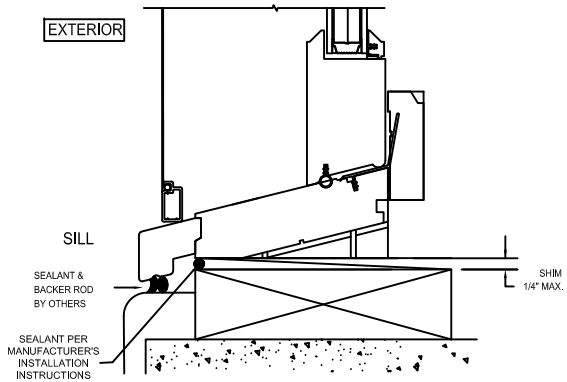
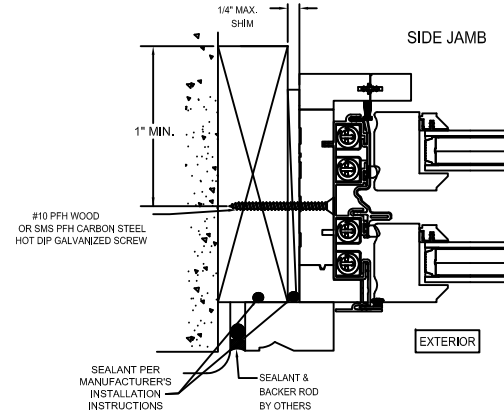
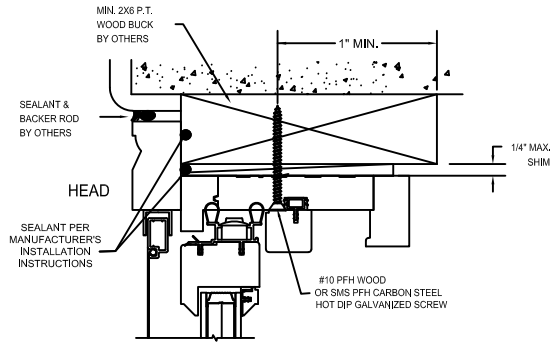

GENERAL NOTES

1. These units have been tested, analyzed, Hallmark certified, and FBC approved.
2. Bucking, openings, and bucking fasteners must be properly designed and installed to transfer wind loads to the structure. The unit was tested with 1/2" rough opening gap.
3. These units were tested with ponderosa pine bucks, Florida building code requires preservative treated southern pine bucks.
4. All hardware and fasteners shall be in accordance with these drawings and may not vary unless specifically mentioned on the drawings.
5. These units have been tested in accordance with and meet the requirements of the Florida Building Code.
6. Impact shutters are required only with non-impact units.
7. All anchors shall be installed as specified on these drawings. Specified embedment base material shall be beyond wall finish or stucco.
8. Testing of one wood species covers all other species with an equal or higher modulus of elasticity and modulus of rupture.
9. Testing of primed covers testing of clad as long as cladding is not structural (extruded), or wraps around the gasket.
10. Testing of windows and doors with a given width and thickness of solid stiles and rails, covers products with wider and thicker solid stiles and rails provided that construction details are consistent.
11. Any fixed geometric shape that fits within the tested/approved size for a particular product type is qualified by the rectangular shape(s) provided that the frame, sash, panels, components, and construction remain the same.
12. All fixed shaped units must fit inscribed into the allowable rectangular units and be governed by allowable design pressure or the respective rectangular unit.
13. Shims need to be located a maximum of 4" from each corner and a maximum of 4" from each anchor location.

KOLBE 1323 South 11th Ave.
Wausau, WI 54401
715-842-5666
■ WINDOWS & DOORS ■

Heritage Series
XL Sterling Double Hung

FL# 25886 R&D No. 15132

Revision Drawn By: JRK

A SES 12/15/20 Date: 12/21/17

B Sheet: 2 of 2

C Drawing No. 15132A